

ALADDIN'S MAGIC LIFT™

Up. Down. Left. Right
Larger. Smaller.

CUSTOM ELEVATING WORK PLATFORMS

- ◆ 306° access to equipment being assembled or serviced
- ◆ Air bearings allow operators to easily move platforms into position
- ◆ Unobstructed work zone beneath platform, with optional lighting
- ◆ Max. Lift Height: 16 feet
- ◆ Lifting Capacity: 2,000 pounds
- ◆ Automatic leveling
- ◆ Optional built-in electrical, pneumatic and hydraulic power outlets
- ◆ One year warranty
- ◆ Made in USA



THE BEST MOVE YOU CAN MAKE

Aladdin Engineering & Manufacturing, Inc.
1100B South Prairie Avenue, Waukesha, WI 53186 USA

AEMSales@AEM-Aladco.com | 262-544-5994 | AladdinEngMfg.com

Small Business Enterprise | Woman-Owned: WBE and WOSB Certifications Pending

The Best Move You Can Make

If you need to safely move personnel off the floor for equipment assembly or service, you need to take a close look at Aladdin's Magic Lift™ from Aladdin Engineering & Manufacturing, Inc.

Aladdin's Magic Lift™ was originally designed for the complex core and coil assembly of electrical transformers. Meeting those demanding requirements has made it ideal for numerous applications that, up to now, have had to deal with the downsides of scaffolding or scissors lifts.

Aladdin's Magic Lift™ pays for itself in bottom-line benefits.

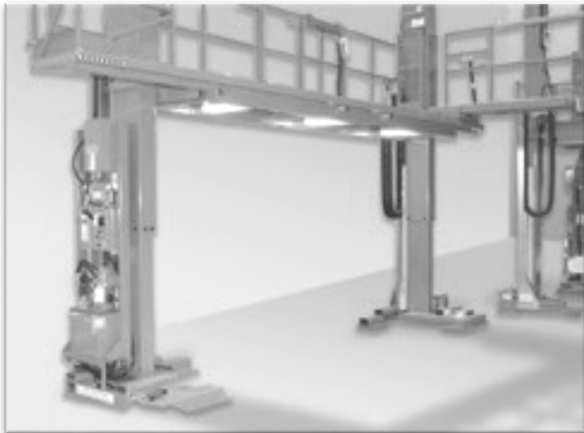

Infinite Flexibility

Position the work platform wherever you need it. From 10 inches to 16 feet off the floor Magic Lift's™ flexible four-way movement enables you to adjust the height, width and depth of your work envelope in virtually infinite increments.

Air bearings at each corner enable two people to easily move the platforms into position. Hydraulic height adjustment is controlled by Aladdin's exclusive telescopic proportional cylinders. Stages extend simultaneously, maintaining smooth, constant speed thru their entire range of motion. Automatic leveling ensures that the platforms stay level.

If your application has unique requirements, we will custom design an Aladdin Magic Lift™ to your specification.

Enhanced Safety

That's the way to attain the highest level of workmanship. Aladdin's Magic Lift™ doesn't leave you up in the air when it comes to safety. Heavy-duty, rigid construction means high capacity. Built-in safety features include non-skid work surfaces, highly audible motion alarms, locking personnel gates, vertical travel lock pins and anchor points for fall protection equipment.

Maximum Productivity

Your employees never have to leave the platform for tools, materials or proper positioning, because Aladdin's Magic Lift™ is more than a platform – it's a totally integrated work/assembly station. Optional built-in electrical, pneumatic and hydraulic power outlets enable you to integrate all necessary tools. Extendable crosswalks between platforms provide 360° access to being serviced. Each platform can be raised or lowered via three separate control panels.

Unlike scaffolding or scissors lifts, Aladdin's Magic Lift™ gives you an additional, unobstructed work zone beneath the platform that even includes lighting on the underside.

Doubling your work zones delivers a quantum leap in efficiency and output, resulting in significantly shorter production cycles.

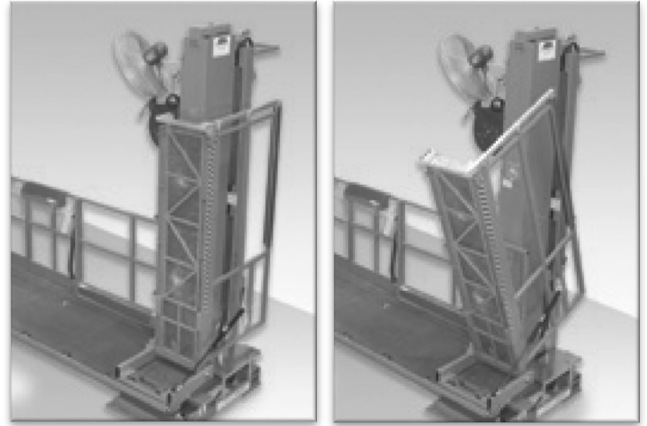

The Quality Equation

Quality is the key to competing in today's market. With Aladdin's Magic Lift™, your employees can be positioned for optimal access and ergonomics for every task at hand. That's the way to attain the highest level of workmanship.

What Aladdin's Magic Lift™ Means for You

Aladdin Engineering & Manufacturing, Inc. has helped industry achieve new levels of quality and production efficiency for over 60 years.

Let us show you the difference Aladdin's Magic Lift™ can make in your application. Call us at 262-544-5994

Aladdin's Magic Lift™ Specifications

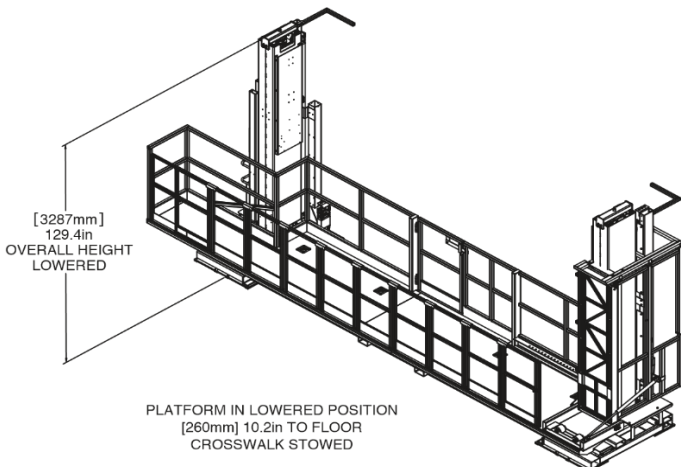
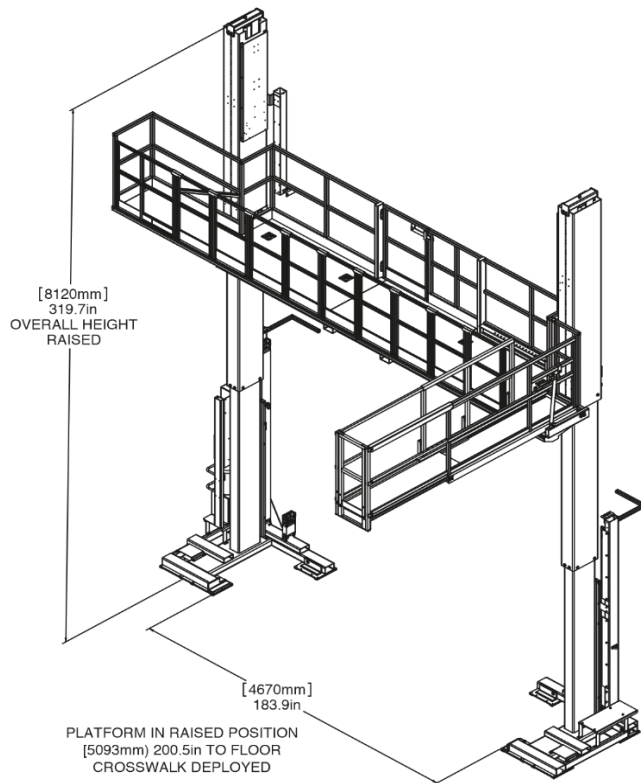
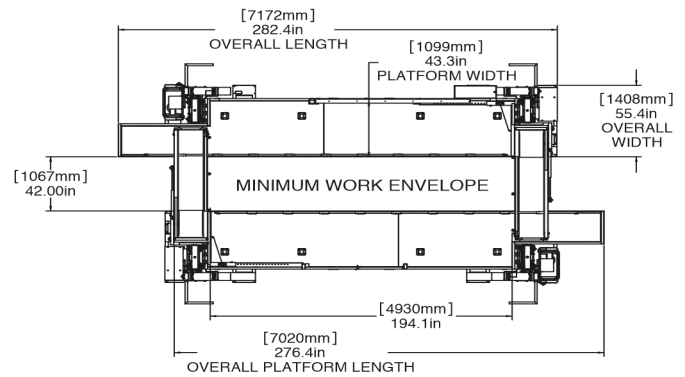
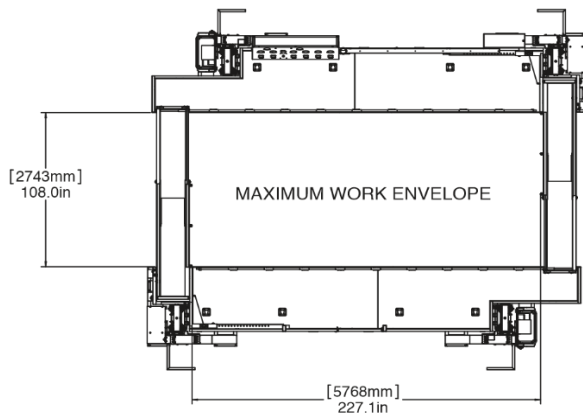

MODEL WS-1600 SPECIFICATIONS

- ◆ Platform height from 10 inches to 16 feet above the floor
- ◆ 45 inch wide non-skid platform
- ◆ Lifting Capacity: 2,000 pounds per platform
- ◆ Optional Crosswalk Load Capacity: 500 pounds
- ◆ Unit Weight: 10,000 pounds
- ◆ Air Bearings for easy positioning (Air Bearings require 80 SCFM @ 30 psi)
- ◆ Vertical Travel speed: 10 feet/minute
- ◆ Electrical Supply: 480 or 240 VAC, 3 Phase
- ◆ Permanent Guard Railings around the outside
- ◆ Removable Guard Rail Sections on the inside
- ◆ Internal Work Envelope with two opposing platforms: 3 feet–7 feet by 10 feet minimum to 9 feet by 19 feet maximum

OPTIONS

- ◆ Extendable Crosswalks
- ◆ 120 VAC Utility Outlets on Platform
- ◆ 120 VAC Power Cord Reels
- ◆ Compressed Air Hose Reels
- ◆ Fans for Worker Comfort
- ◆ Under Platform Lighting
- ◆ Power System for Hydraulic Tools
- ◆ Overhead Tool Support Beam
- ◆ Custom Color Schemes
- ◆ Custom Sized Platforms